

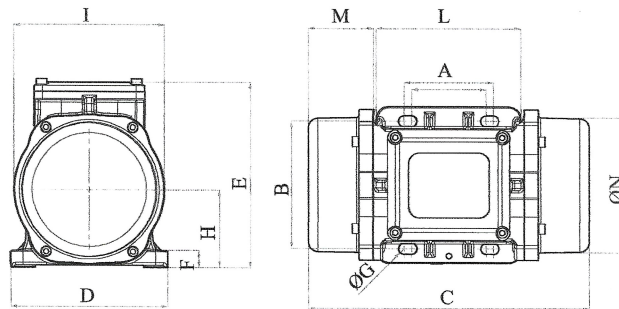

# MVE 200/3X-20A0 [EX20020020A0JA0000]

3 PH - 2 poles - 3000 RPM - 220-240/380-415 V - 50 Hz

Working moment (Kg*cm)	Unbalance (Kg*cm)	Centrifugal force (Kg)	Nominal voltage (V)	Input power (kW)	Current (A)	Power factor	Ia/In
3,71	1,86	187	220-240/380-415	0,15	Δ 0,61 Y 0,35	0,62	3,5



\*Technical drawings are illustrative purposes only, please refer to 2D/3D drawings available on "FINDER" app. Contact us for more information.

OVERALL DIMENSIONS (mm)													
Weight (Kg)	A	B	G	Holes number	C	D	E	F	H	I	L	M	N
7	62-74	106	9	4	233	130	154	15	65	125	120	54	112

TECHNICAL FEATURES						
Type of grease	Greased for life	Screw	Washer	Clamping torque (Nm)	Cable type	Cable gland
/	Yes	M8	8,4 x 16 mm	23	4G2.5 80°C	M20 80°C

BEARINGS LIFE HOURS				
Bearing model	Type	100% C.F	80% C.F	50% C.F
6302 ZZ		5522	10785	44176

CERTIFICATION	
II 2G Ex eb IIC Tx Gb, II 2D Ex tb IIIC Tx Db IP66 Ex eb IIC T3 Gb Ex tb IIIC Tx Db IP66 CLASS I DIV.2 GROUP A,B,C,D T3 CLASS II DIV.2 GROUP F,G T4 Ex ec IIC T3 Gb Ex tb IIIC Tx Db IP66 CONFTO UL1004-3, UL1004-1, UL 60079-0, UL60079-7, UL60079-31 CERT. CSA C22.2 No.100, CSA C22.2 No.77, CSA C22.2N.60079-0, CSA C22.2N.60079-7, CSA C22.2N. 60079-31 T.Amb -20/+40°C [Tx Size 20-30:100°C - Tx Size 40-91:135°C]	