

F - Adjustable

AERATORS

AIR JET

The pneumatic vibrators of the F range generate linear vibration thanks to the movement of a floating piston. To meet different application needs, the F series is

available in various shapes, sizes and materials. It is possible to apply additional masses to the piston in order to modify the frequency and the force developed.



PNEUMATIC LINEAR

PNEUMATIC ROTARY

ELECTRIC

DRAULIC

F - ADJUSTABLE - PNEUMATIC LINEAR VIBRATORS

APPLICATION	Vibrating feeder - table and channel
POWDER	Hygroscopic - dusty and granular
PROBLEM SOLVING	Bridge and rat-holing - detaching and compacting
FEATURES	
DUTY CYCLE	Continuous
WORKING PRESSURE	From 2 bar to 6 bar (from 29 psi to 87 psi)
PNEUMATIC CIRCUIT	Filter + flow control valve + lubrication + 3/2 ways valve N.C.
AIR SUPPLY QUALITY	Class 5.4.4.
WORKING TEMPERATURE	From -20 °C to 200 °C [from -4 °F to 392 °F] F15P - from -20 °C to 100 °C [from -4 °F to 212 °F]
MAX NOISE LEVEL	80 dB(a)
TECHNOLOGY	Adjustable piston
ATEX	II 2D c Tx II 2G c Tx
MATERIAL	Grey cast iron body (powered painted) F15P: nylon body and aluminium cover F18: aluminium body (square shape)

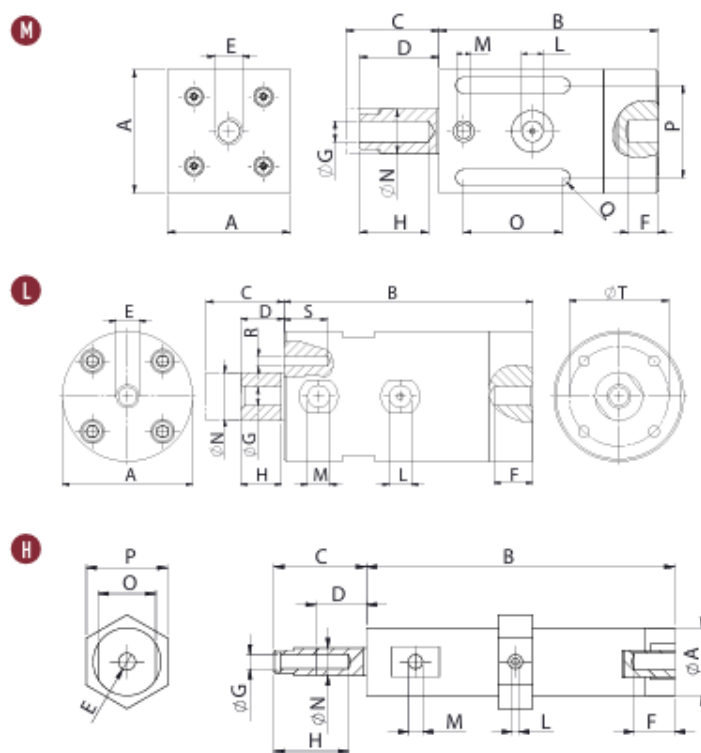

DIMENSIONAL SPECIFICATIONS

Model	Draw.	A		B		C		D		E		F		G		H		I		L		M		N		O		P		Q		R		S		T		Weight		
		mm	in	mm	in	mm	in	mm	in	mm	in	mm	in	mm	in	mm	in	mm	in	mm	in	mm	in	mm	in	mm	in	mm	in	mm	in	mm	in	mm	in	kg	lb			
F8	H	20	0.8	91	3.6	30	1.2	5	0.2	M6	10	0.4	M5	20	0.8	7	0.3	M5	M5	8	0.3	17	0.7	24	0.9	/	/	/	/	/	/	/	/	/	/	/	/	0.1	0.2	
F15	L	50	2.0	115	4.5	41	1.6	7	0.3	M10	15	0.6	M10	15	0.6	13	0.5	1/8" BSPP	1/8" BSPP	15	0.6	12	0.5	/	/	/	/	/	/	/	/	/	/	/	/	/	/	1.5	3.3	
F15P	L	50	2.0	115	4.5	39	1.5	9	0.4	M10	15	0.6	M10	22	0.9	13	0.5	1/8" BSPP	1/8" BSPP	16	0.6	/	/	/	/	/	/	/	/	/	/	/	/	/	/	/	/	0.5	1.1	
F18	M	50	2.0	89	3.5	32	1.3	10	0.4	M10	10	0.4	M10	26	1.0	12	0.5	1/8" BSPP	1/8" BSPP	18	0.7	40	1.6	38	1.5	7	0.3	/	/	/	/	/	/	/	/	/	/	/	0.6	1.3
F25	L	60	2.4	115	4.5	45	1.8	10	0.4	M10	15	0.6	M10	15	0.6	19	0.8	1/4" BSPP	1/4" BSPP	22	0.9	15	0.6	/	/	/	/	/	/	/	/	/	/	/	/	/	/	2.3	5.1	
F40	L	85	3.4	140	5.5	57	2.2	13	0.5	M16	17	0.7	M16	20	0.8	36	1.4	1/4" BSPP	3/8" BSPP	40	1.6	20	0.8	/	/	/	/	/	/	/	/	/	/	/	/	/	/	5.7	12.5	
F85	L	160	6.3	122	4.8	52	2.1	22	0.9	M20	30	1.2	M20	30	1.2	/	/	3/8" BSPP	2x3/8" BSPP	85	3.3	/	/	/	/	/	/	/	/	/	/	/	/	/	/	/	140	5.5	16.5	36.3

Model	2 BAR								4 BAR								6 BAR										
	Vibr.		Force		Working moment		Air consumption		Vibr.		Force		Working moment		Air consumption		Vibr.		Force		Working moment		Air consumption				
	V/min	N	lb	kgcm	inlb	l/min*	cfm	V/min	N	lb	kgcm	inlb	l/min*	cfm	V/min	N	lb	kgcm	inlb	l/min*	cfm	V/min	N	lb	kgcm	inlb	l/min*
F8	2020	9.1	2	0.04	0.04	7	0.2	2950	19.3	4.3	0.04	0.04	19	0.7	3600	28.8	6.5	0.04	0.04	28	1.0						
F15	2280	75.7	17	0.27	0.23	20	0.7	2520	92.5	20.8	0.27	0.23	38	1.3	2820	115.9	26	0.27	0.23	67	2.4						
F15P	1920	54.5	12.3	0.27	0.23	20	0.7	2160	69.0	15.5	0.27	0.23	42	1.5	2340	81	18.2	0.27	0.23	80	2.8						
F18	2070	71.8	16.1	0.31	0.27	29	1.0	2520	106.4	23.9	0.31	0.27	55	1.9	3300	182.5	41	0.31	0.27	100	3.5						
F25	1860	108	24.3	0.57	0.49	32	1.1	2040	129.9	29.2	0.57	0.49	60	2.1	2220	179.8	40.4	0.57	0.49	105	3.7						
F40	1380	259.6	58.3	2.49	2.16	80	2.8	1560	331.8	74.6	2.49	2.16	190	6.7	1740	412.8	92.8	2.49	2.16	320	11.2						
F85	1680	2137.2	480.3	13.82	12.00	240	8.4	1980	2968.6	667.1	13.82	12.00	390	13.7	2280	3936.3	884.6	13.82	12.00	580	20.4						

* Indicates in l/min the total air consumption normalized at the rated pressure.